

Operation Manual

P7183ENF

! IMPORTANT: THIS OPERATING MANUAL CONTAINS IMPORTANT SAFETY INFORMATION, READ CAREFULLY & UNDERSTAND ALL INFORMATION BEFORE OPERATING. SAVE THIS MANUAL FOR FUTURE USE



Do not open more than one drawer at a time.



Do not step on drawers.



Do not let children near the Toolbox.



Do not separate Chest from Trolley.



Do not exceed Drawer Load Limit



Not suitable for mounting in Vehicles



Set the brake on the locking castors unless you are moving the Toolbox.



Lock drawers and lid before moving the Toolbox.



Specifications

Tray Load Capacity	45kg
Net Weight	29kg
Material	Heavy Gauge Steel
Overall Measurements	L 938 x W 750 x H 965mm
Top Tray	L 465 x W 750 x H 59mm
Middle Tray	L 465 x W 750 x H 59mm
Bottom Tray	L 465 x W 750 x H 78mm

Parts List

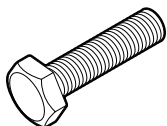

16 X BOLTS FOR CASTORS
(13MM X 16 BOLTS)

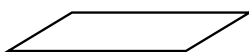

3 X EVA MATS



2 X LOCKABLE SWIVEL CASTORS



2 X SWIVEL CASTORS

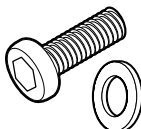

32 X 5MM HEX BOLTS & WASHERS

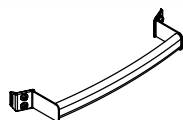

1 X TROLLEY HANDLE WITH 2X STAINLESS STEEL WASHERS

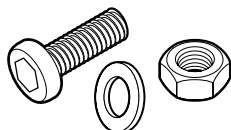

4 X 5MM HEX BOLTS, WASHERS & NUTS FOR TROLLEY HANDLE

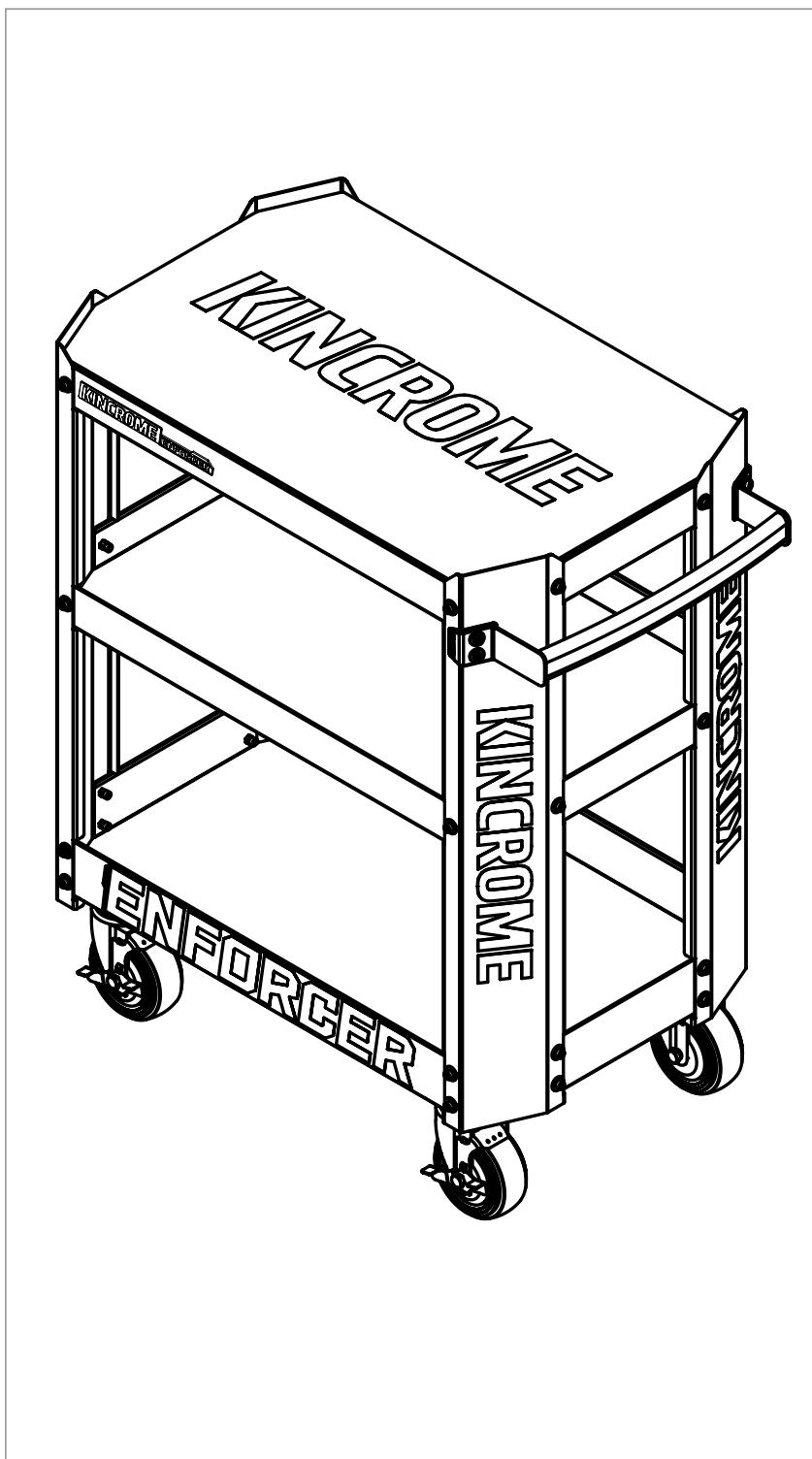

Maintenance

- > Periodically tighten all hardware
- > Periodically lubricate castors
- > Use a damp Microfibre cloth to clean all surfaces

Operation Manual

1 Assembling Shelves

TOOLS REQUIRED:



5MM HEX KEY

STEP 1:

Remove all contents from carton and reference the parts list ensuring you have all the parts

STEP 2:

Starting with the base shelf attach each vertical upright using the supplied 5mm hex bolts and washers

NOTE: Do not fully tighten hex bolts until unit is assembled

STEP 3:

Repeat Step 1 for the middle and top shelf

NOTE: Fit the top shelf according to your preference, either Flat style or Tray style

STEP 4:

Tension all hex bolts ensuring they are tight

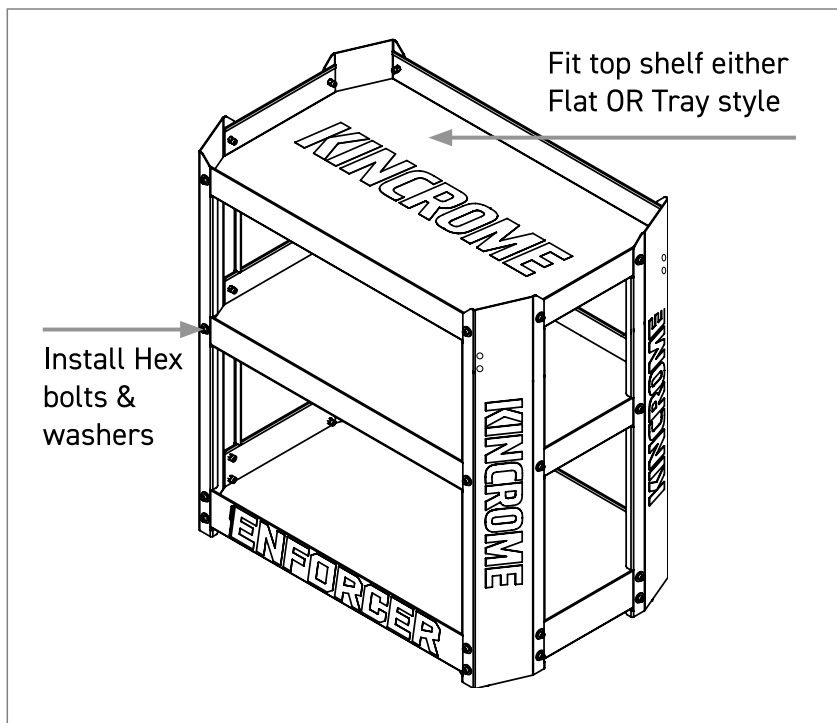

2 Attaching Castors

TOOLS REQUIRED:

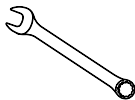

13MM SPANNER

STEP 1:

Carefully lie the Cart on its side and fit the 4 swivel castors using the bolts & washers provided.

STEP 2:

Please ensure they are tightly fastened.

NOTE:

Fix locking Castors on the cart at the same end you plan to install the handle.

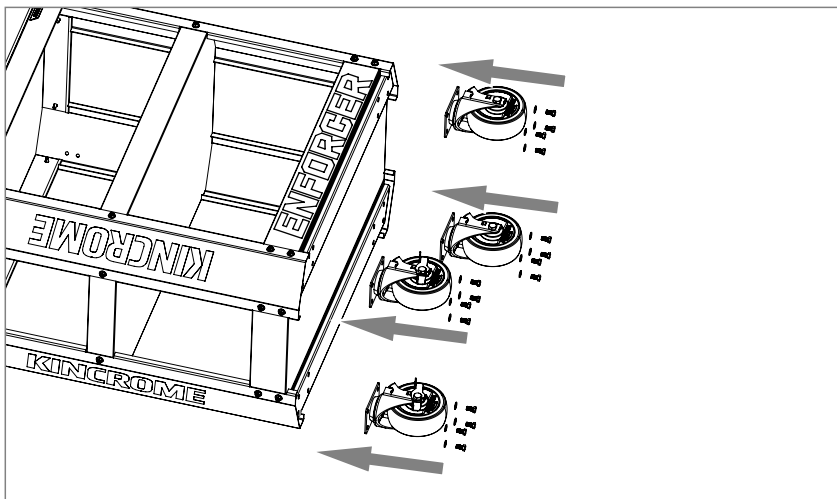

3 Attaching Handle

TOOLS REQUIRED:



5MM HEX KEY

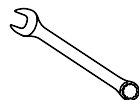

10MM SPANNER

STEP 1:

Stand the Cart back on the castors and fit the side handle using the Hex bolts with nuts & washers provided. The decorative stainless steel washers are bolted between the cart handle and uprights. The handle can be fitted on either side of the cart.

STEP 2:

Attach the Kincrome ENFORCER badge as shown in the drawing (or to your preference). Insert each EVA tray liner into the shelves, placing the thicker liner on the top shelf.

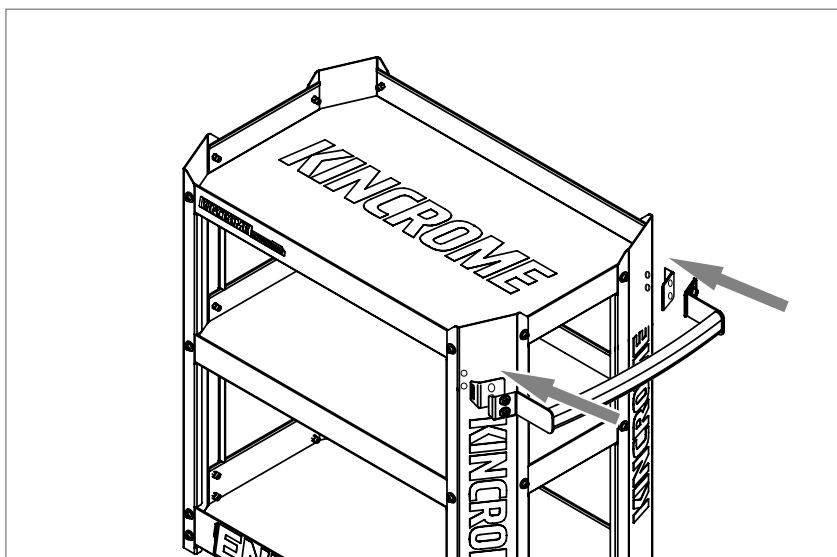

Spare Parts

P7183ENF

Spare Parts - P7183ENF

Ref	Part Number	QTY	Description
1	K79983	2	SWIVEL CASTOR CART BLACK X1
2	K79984	2	SWIVEL CASTOR LOCK CART BLACK X1
3	K79985	1	CART EVA TOP LINER 5MM X1
4	K79986	2	CART EVA SHELF LINER 2MM X1
5	K79988	1	CART HANDLE BLACK X1

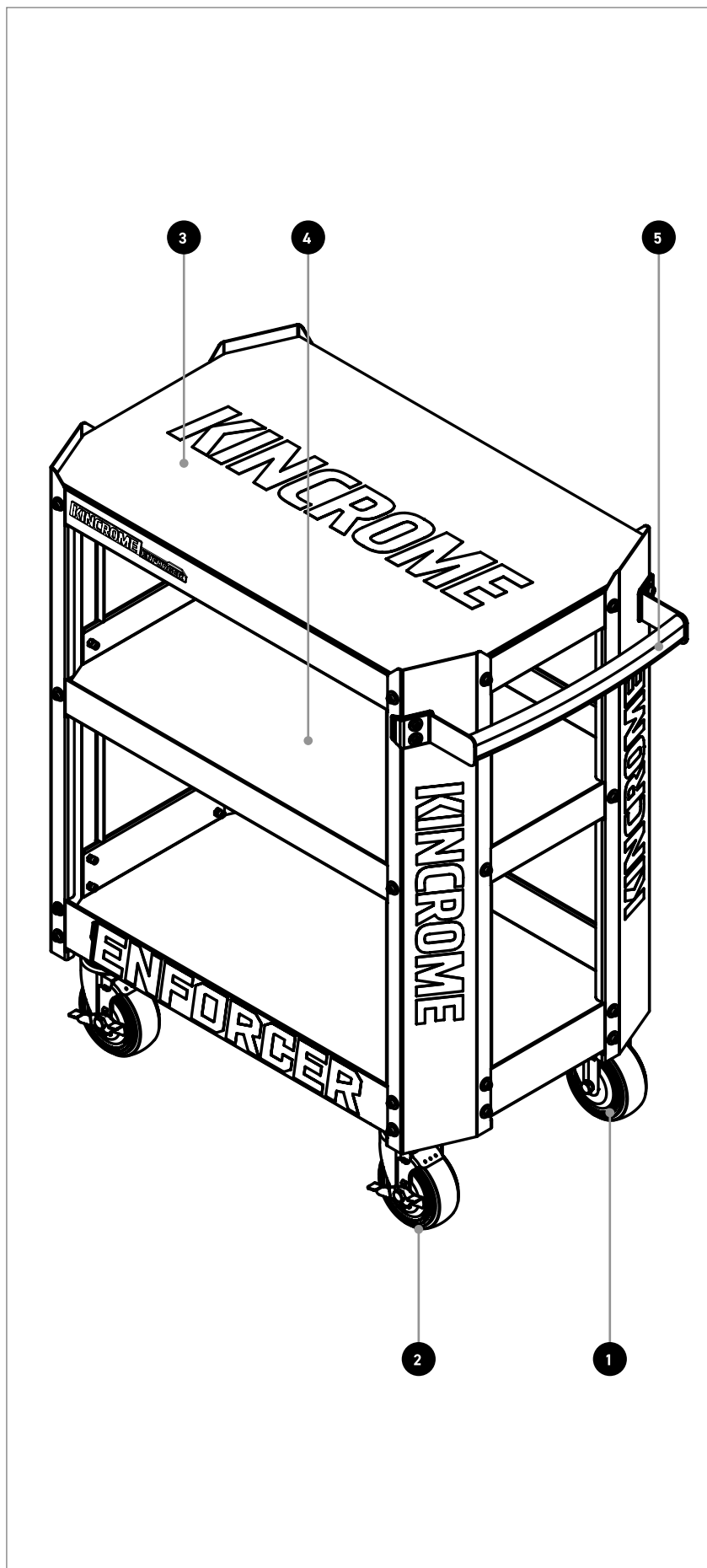

OFFICE CONTACT DETAILS

 Phone: 1300 657 528  Email: enquiries@kincrome.com.au  Website: www.kincrome.com.au

WARRANTY**3 YEAR
WARRANTY**

Our goods and services come with guarantees that cannot be excluded under the Australian Consumer Law. For major failures with the service, you are entitled: -to cancel your service contract with us; and -to a refund for the unused portion, or to compensation for its reduced value. You are also entitled to choose a refund or replacement for major failures with goods. If a failure with the goods or a service does not amount to a major failure, you are entitled to have the failure rectified in a reasonable time. If this is not done you are entitled to a refund for the goods and to cancel the contract for the service and obtain a refund of any unused portion. You are also entitled to be compensated for any other reasonably foreseeable loss or damage from a failure in the goods or service'. Kincrome Australia Pty Ltd of 3 Lakeview Drive, Caribbean Park, Scoresby, Victoria (Tel 1300 657 528) also provides the Kincrome Limited Lifetime Guarantee, 5 Year Warranty, 5 Year (3+2) warranty, 3 Year Warranty, 2 Year Warranty and 12-Month Warranty (Kincrome Express Warranties) in respect of some of its products. If a product is covered by a Kincrome Express Warranty and it has materials or workmanship defects (other than defects caused by abnormal or non warranted use) which are covered under the terms of the relevant Kincrome Express Warranty, you can, at your cost, send the product to the above address for repair or replacement. Your rights under a Kincrome Express Warranty are in addition to any other rights you have under the Australian Consumer Law or other applicable laws. For further details and terms please check our product guide, visit www.kincrome.com.au or call us. Every effort is made to ensure advertised stock is available, but due to factors beyond the control of Kincrome Australia Pty. Ltd, not all products advertised in this catalogue may be available at all stores. Kincrome Australia Pty. Ltd. reserves the right to correct printing errors. All sizes shown are approximate only. Accessories shown do not come with the product unless otherwise specified. Due to printing process, colours in this catalogue may vary slightly to actual item. E. & O. E.© Copyright 2022. Reproduction in whole or in part is prohibited without written approval.