

# Operation Manual

K77820

**! IMPORTANT:** THIS OPERATING MANUAL CONTAINS IMPORTANT SAFETY INFORMATION, READ CAREFULLY & UNDERSTAND ALL INFORMATION BEFORE OPERATING. SAVE THIS MANUAL FOR FUTURE USE



Do not open more than one drawer at a time.



Do not step on drawers.



Do not let children near the Toolbox.



Do not separate Chest from Trolley.



Do not exceed Drawer Load Limit.



Not suitable for mounting in Vehicles.



Lock drawers and lid before moving the Toolbox.



## Specifications

Net Weight	66kg
Material	Heavy Gauge Steel
Measurements	W 1450 x L 625 x H 508mm

## Parts List



2 X KEYS

## Packaging Contents

### HARDWARE INCLUDED

Note: Hardware not shown to actual size.

Note: Begin product assembly close to the final intended location of your cabinet. The product is heavy and may be difficult to move after assembly.

Part Number	QTY	Description
AA	4	ROUND HEAD FLAT BOLT (M8*60MM)
BB	4	WASHER
CC	1	EVA SPACER

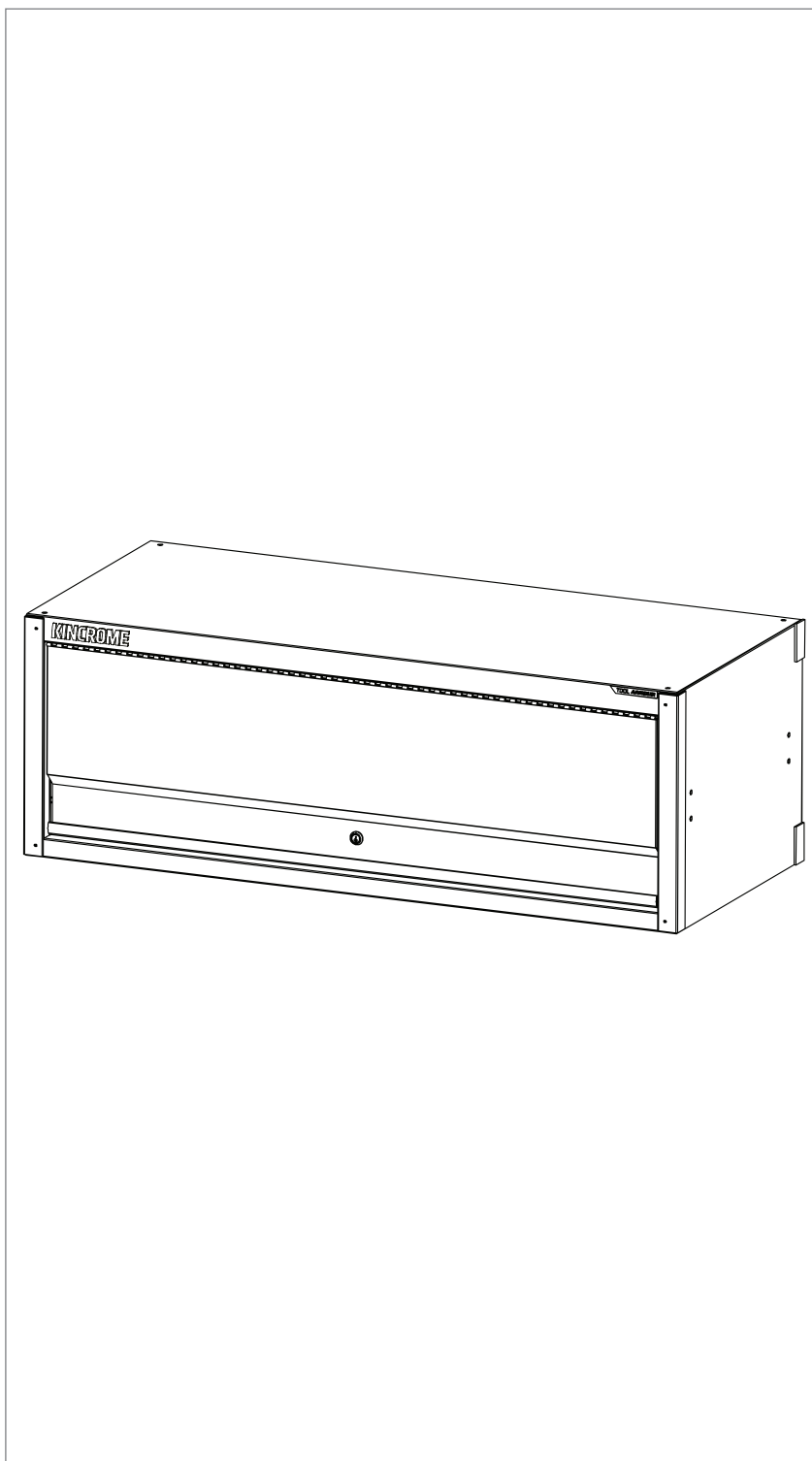
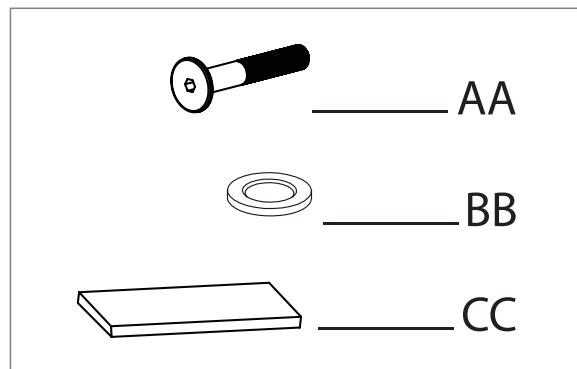

## Maintenance

- > Periodically tighten all hardware
- > Lubricate the lock with graphite annually
- > Use a damp Microfibre cloth to clean all surfaces

# Operation Manual

K77820

## Assembly

### SETTING THE TOP LOCKER

- Peel off the paper back from the EVA Spacers (CC), and affix in the appropriate position toward the rear of the Top Locker (A).
- Gently place the Top Locker to the top left side of the existing Hutch and Side Locker.

**Note:** Side Lockers are required on both sides of the Tool Trolley and Hutch in order for the Top Locker installation.

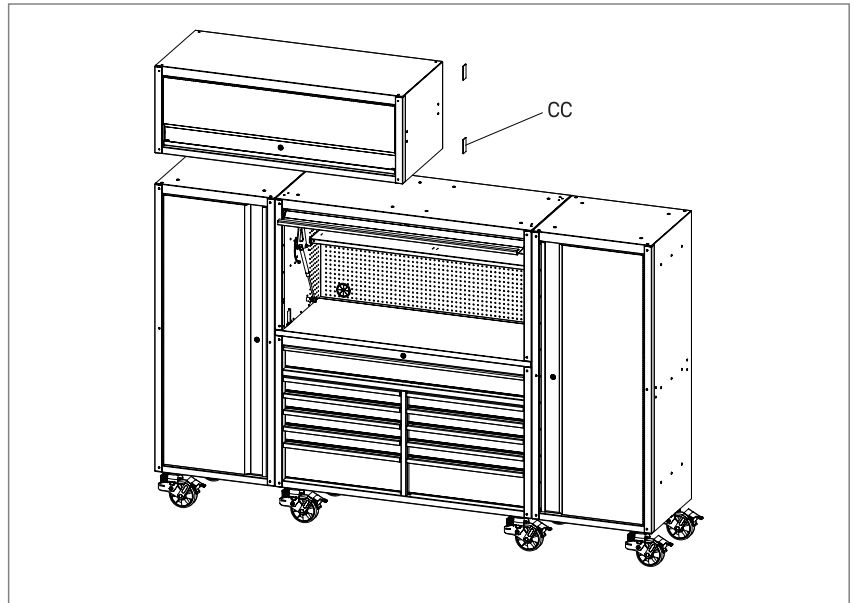

### ATTACH THE TOP LOCKERS TO THE HUTCH & SIDE LOCKER

- Open the Top Locker door.
- Attach the Top Locker (A) using 4 pcs M8\*60 flat bolts (AA) and 4 pcs washers (BB) with Hex Key in the 4 corners.
- Do not tighten bolts until both lockers are attached and flush.

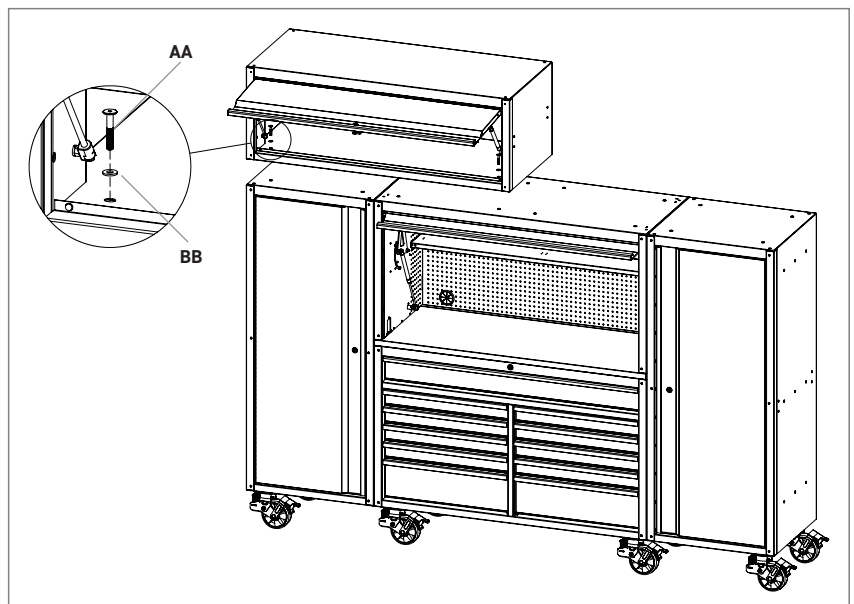

- Once both Top Lockers are attached and the front and top edges are flush with the existing Hutch and Side Lockers, then tighten all 8 bolts (AA). Be careful not to overtighten.

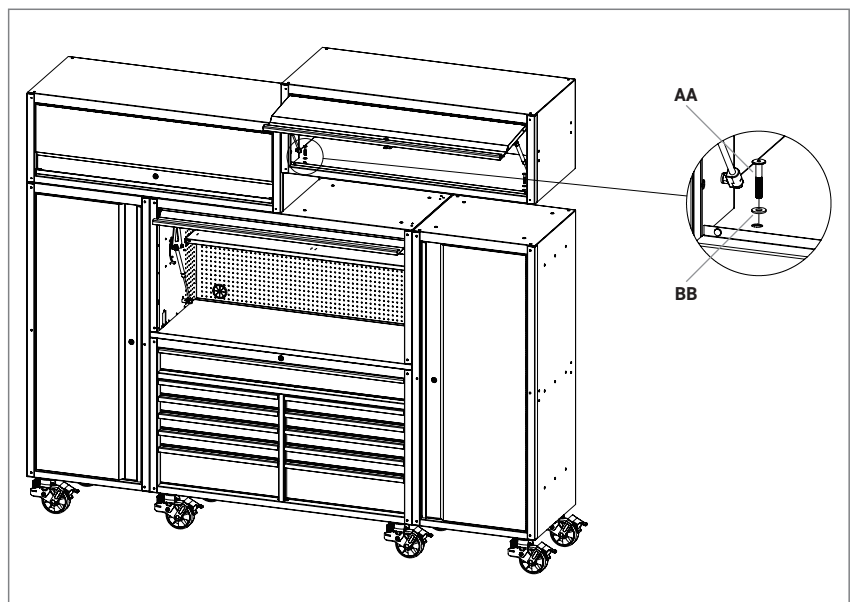

## Operation Manual

K77820

### General Safety Warnings

1. To reduce the risk of injury, please read and follow the safety instructions below before assembling and using this product.
2. Two or more people are required for the assembly of this product.
3. Secure this product properly before moving it with a forklift.
4. Do not tow the product with power equipment.
5. Do not alter this product in any manner. For example, do not weld external lock bars or attach electrical equipment.



**Caution:** Do not attach or mount this product to a vehicle or mobile trailers. This may cause personal injury or product damage. Mounting this product to any vehicle or mobile trailers in any manner will void warranty.



**Caution:** Keep the product on level surfaces. The product may become unstable and tip if stored or moved on an unlevel surface, which may cause personal injury or product damage.





**Caution:** Lock the door before moving this product. The door could come open and make the product unstable, which may cause personal or product damage.

### Spare Parts

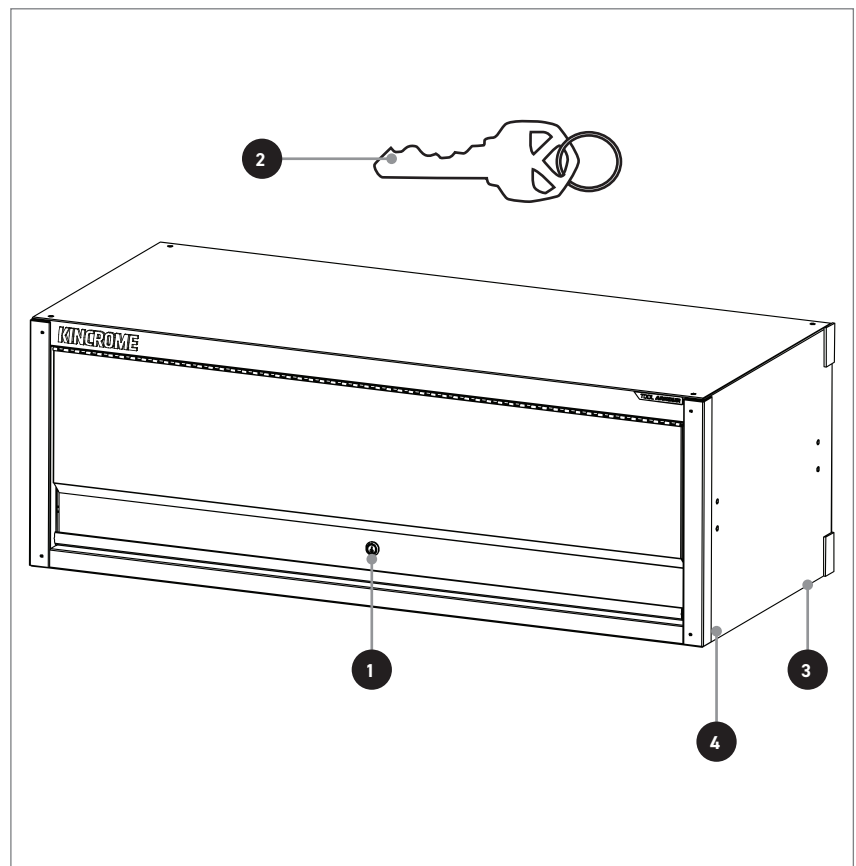
Ref	Part Number	QTY	Description
1	K77999-2	1	HUTCH/TOP/SIDE LOCKER LOCK & KEYS
2	K77999-6	1	KEYS ONLY
3	K77999-13	2	CABLE GROMMET X 1
4	K77999-22	1	TOP LOCKER BOLT PACK



**OFFICE CONTACT DETAILS**

 Phone: 1300 657 528  Email: [enquiries@kincrome.com.au](mailto:enquiries@kincrome.com.au)  Website: [www.kincrome.com.au](http://www.kincrome.com.au)

**WARRANTY**

Our goods and services come with guarantees that cannot be excluded under the Australian Consumer Law. For major failures with the service, you are entitled: -to cancel your service contract with us; and -to a refund for the unused portion, or to compensation for its reduced value. You are also entitled to choose a refund or replacement for major failures with goods. If a failure with the goods or a service does not amount to a major failure, you are entitled to have the failure rectified in a reasonable time. If this is not done you are entitled to a refund for the goods and to cancel the contract for the service and obtain a refund of any unused portion. You are also entitled to be compensated for any other reasonably foreseeable loss or damage from a failure in the goods or service'. Kincrome Australia Pty Ltd of 3 Lakeview Drive, Caribbean Park, Scoresby, Victoria (Tel 1300 657 528) also provides the Kincrome Lifetime Guarantee and 12-Month Warranty (Kincrome Express Warranties) in respect of some of its products. If a product is covered by a Kincrome Express Warranty and it has materials or workmanship defects (other than defects caused by abnormal or non warranted use) which are covered under the terms of the relevant Kincrome Express Warranty, you can, at your cost, send the product to the above address for repair or replacement. Your rights under a Kincrome Express Warranty are in addition to any other rights you have under the Australian Consumer Law or other applicable laws. For further details and terms please check our product guide, visit [www.kincrome.com.au](http://www.kincrome.com.au) or call us. Every effort is made to ensure advertised stock is available, but due to factors beyond the control of Kincrome Australia Pty. Ltd, not all products advertised in this catalogue may be available at all stores. Kincrome Australia Pty. Ltd. reserves the right to correct printing errors. All sizes shown are approximate only. Accessories shown do not come with the product unless otherwise specified. Due to printing process, colours in this catalogue may vary slightly to actual item. E. & O. E.© Copyright 2022. Reproduction in whole or in part is prohibited without written approval.